

SIRUBA®

銀箭牌工業用縫紉機

INDUSTRIAL SEWING MACHINE

F007K/FHK

使用說明書與零件圖
INSTRUCTION BOOK &
PARTS LIST

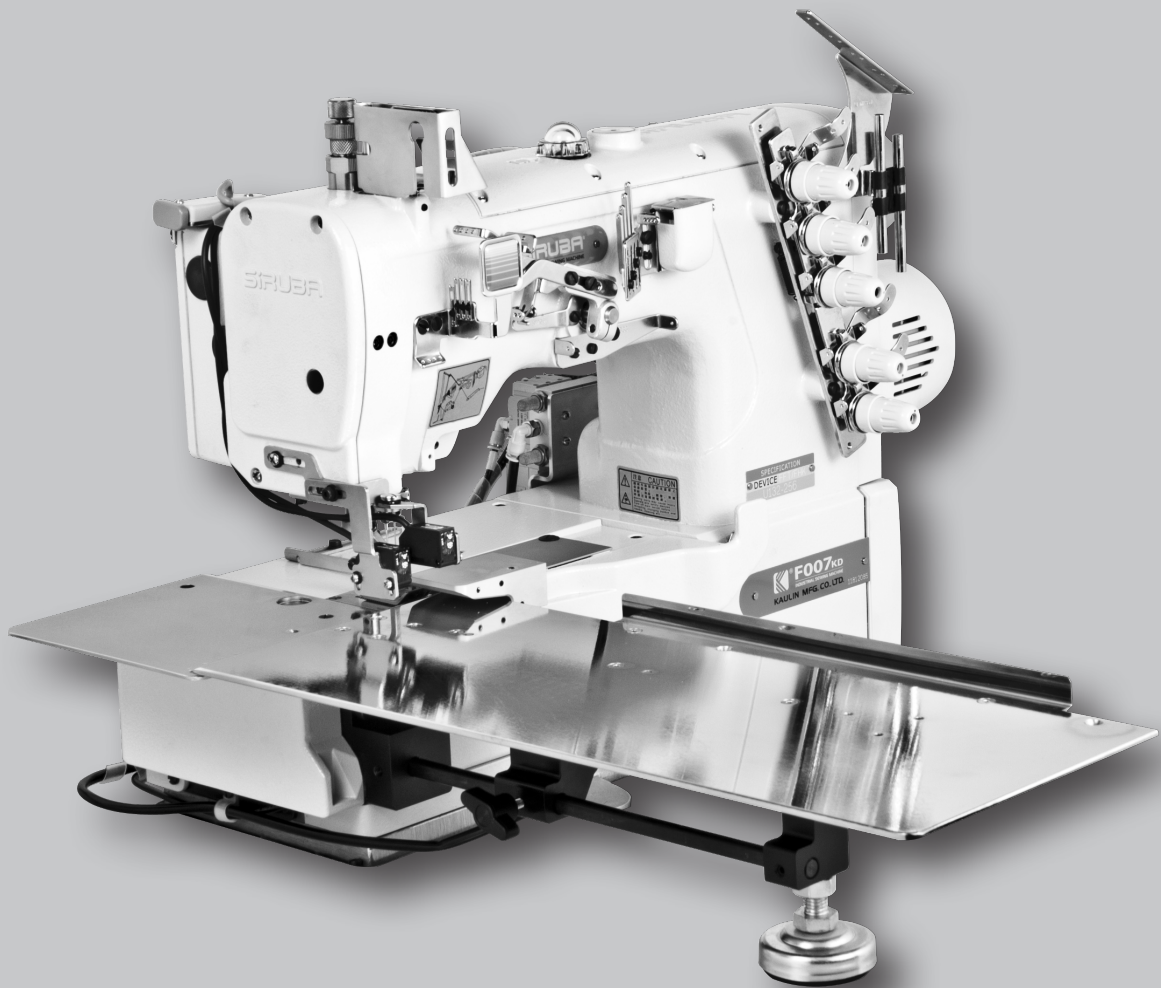

CE



高林股份有限公司
KAULIN MFG. CO., LTD.

產品規格**PRODUCT SPECIFICATION**

1. 規格

1. Specification

規格 Specifications	標準值 Standard value
針棒行程 Needle bar stroke	33±0.5 mm
左針高度 Left needle height	10 mm
送具高度 Feed dog height	0.8~1.2 mm
押具揚程 Presser foot lift	5 mm
使用針 Needle	UYX128GAS#10
上送齒上下行程 Top and bottom stroke for top feed teeth	4 mm
上送齒前後行程 Front and back stroke for top feed teeth	1~5.5 mm 可調式 adjustable
啟動扭力 Start up torque	3.5 kg-cm 以下 Below 3.5 kg-cm
最高轉速 Maximum speed	4000 s.p.m
噪音值 Noise level	80dB(A) 以下 Below 80dB(A)
上送齒與下送具最小距離 The minimum distance between top feed teeth and bottom feed dog	0.5 mm

安裝

INSTALLATION

將螺絲 ①、② 從機體旋出後，將導布片 ③ 以螺絲 ①、② 固鎖在機體。(圖1)

Loosen screws ①, ② and then fix fabric guide plate ③ to the machine with screws ①, ② (Fig. 1)

將導布片 ③ 以螺絲 ①*2墊片 ②*2固鎖在導布塊 ④ 上。(圖2)

Fix fabric guide plate ③ to fabric guide block ④ with screws *2 and spacers ④ *2 (Fig. 2)

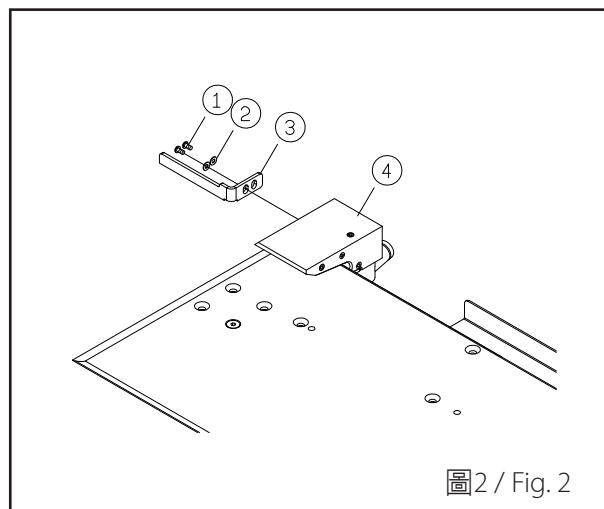
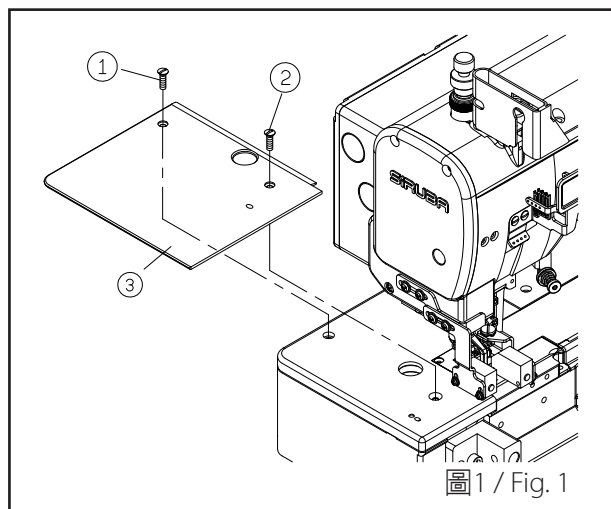

將固定腳座 ① 固鎖在固定塊 ② 上。(圖3)

Fix the base ① on the block ② . (Fig. 3)

鬆開螺絲 ① *2將軸 ② 軸 ③ 放置於固定塊 ④ 中，再將螺絲 ① *2鎖緊。(圖4)

Loosen screws ① *2 and place shafts ② and ③ into fixed block ④ . Tighten screws ① *2. (Fig. 4)

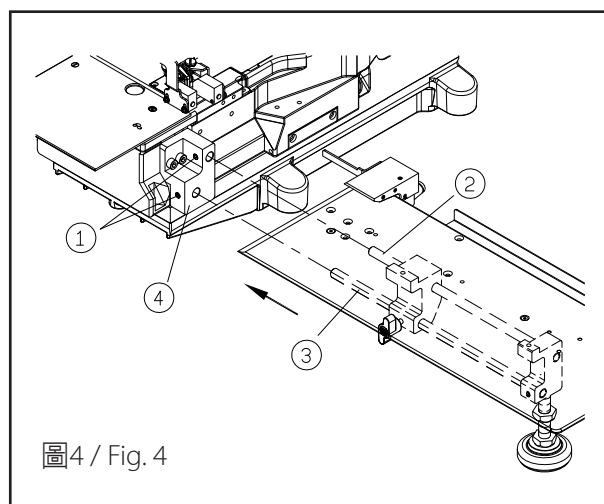
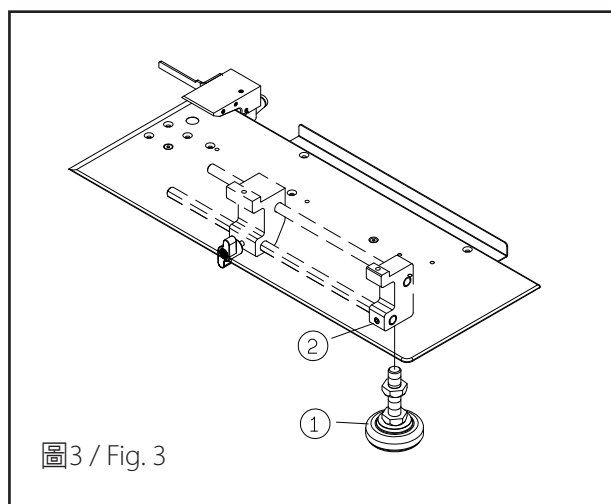

安裝

INSTALLATION

調整固定腳座 ① 使導布架平整置放於導布板上，旋轉螺帽 ② 固定導布架高度。（圖5）

Adjust the base ① to make the fabric feeding plate even. Adjust the nut 2 to set the height. (Fig. 5)

將導布片 ① 以螺絲 ② *2 固鎖在桌板上，鎖固時需注意 ③ 面需與 ④ 面對齊，⑤ 面與 ⑥ 面對齊。（圖6）

Fix fabric guide plate ① to the table with screws ② *2. Notice that B side has to be aligned with ④ side, and ⑤ side has to be aligned with ⑥ side. (Fig. 6)

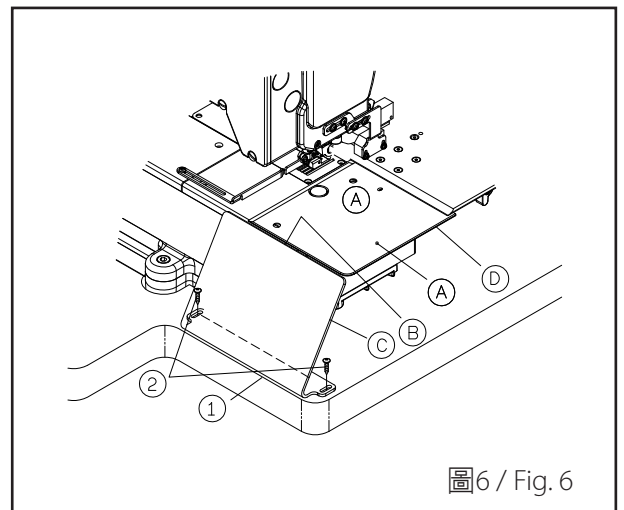
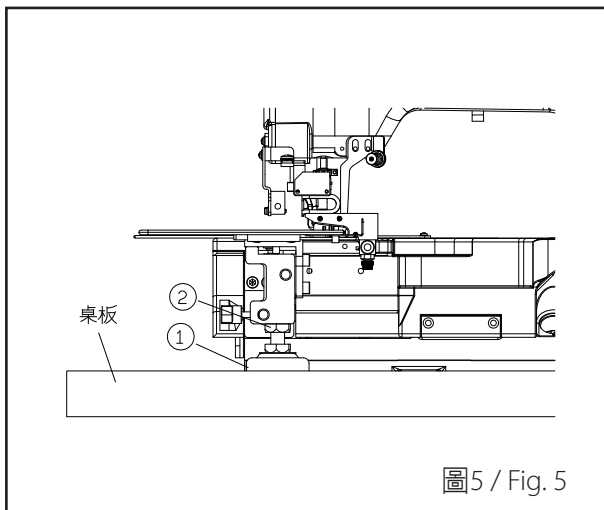

將空壓管 ① 裝入接頭 ② 中。（圖7）

Attach tube ① to connector ②. (Fig. 7)

配件鎖固後將SENSOR ① 轉約90°後，並測試燈號是否有作用。（圖8）

Turn SENSOR ① about 90°. And whether the lamp signal works. (Fig. 8)

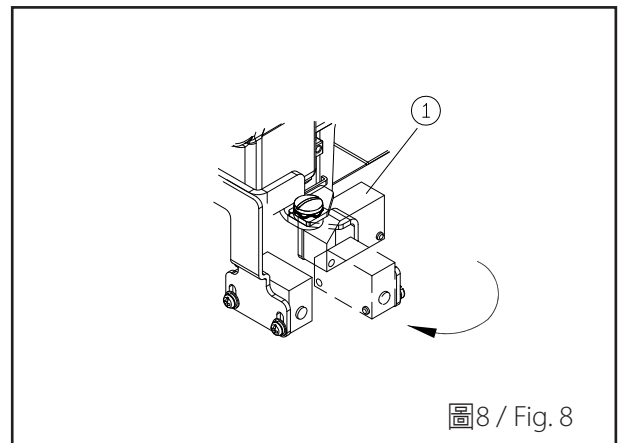
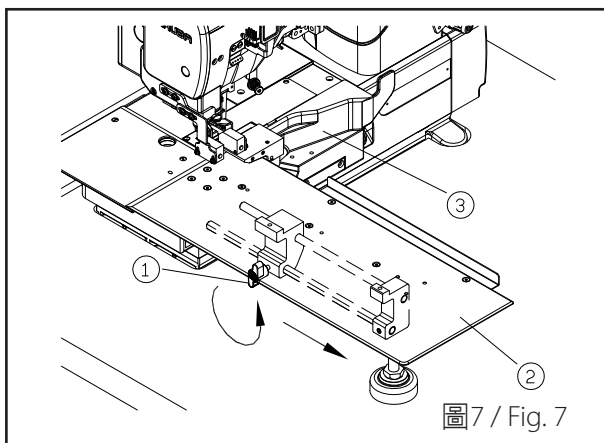

鬆開螺絲① *2調整導布片② 與導布片③ 對齊。
(圖9)

Loosen screws① *2 Adjust fabric guide pate② so
that it is aligned with fabric guide plate ③ . (Fig. 9)

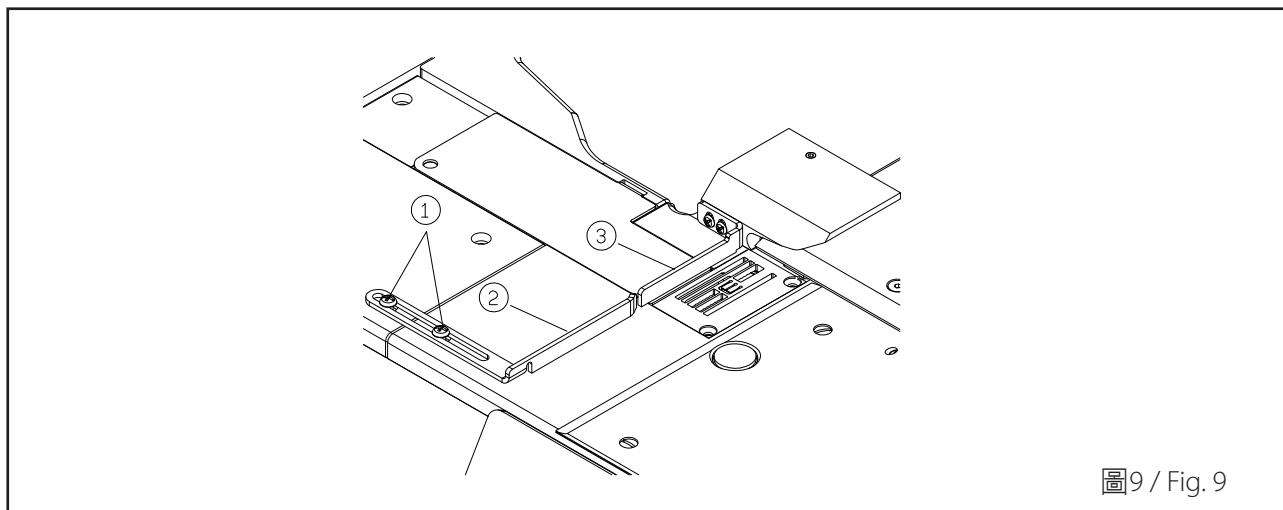

各部件名稱

PART NAMES



圖10 / Fig. 10

- ① 電眼組
- ② 導布板
- ③ 導布板
- ④ 導布板組
- ⑤ 桌板
- ⑥ 調整過濾器
- ⑦ 腳踏板

- ① Electric eye set
- ② Fabric guide plate
- ③ Fabric guide board
- ④ Fabric guide board set
- ⑤ Table
- ⑥ Adjusting filter
- ⑦ Pedal

調整

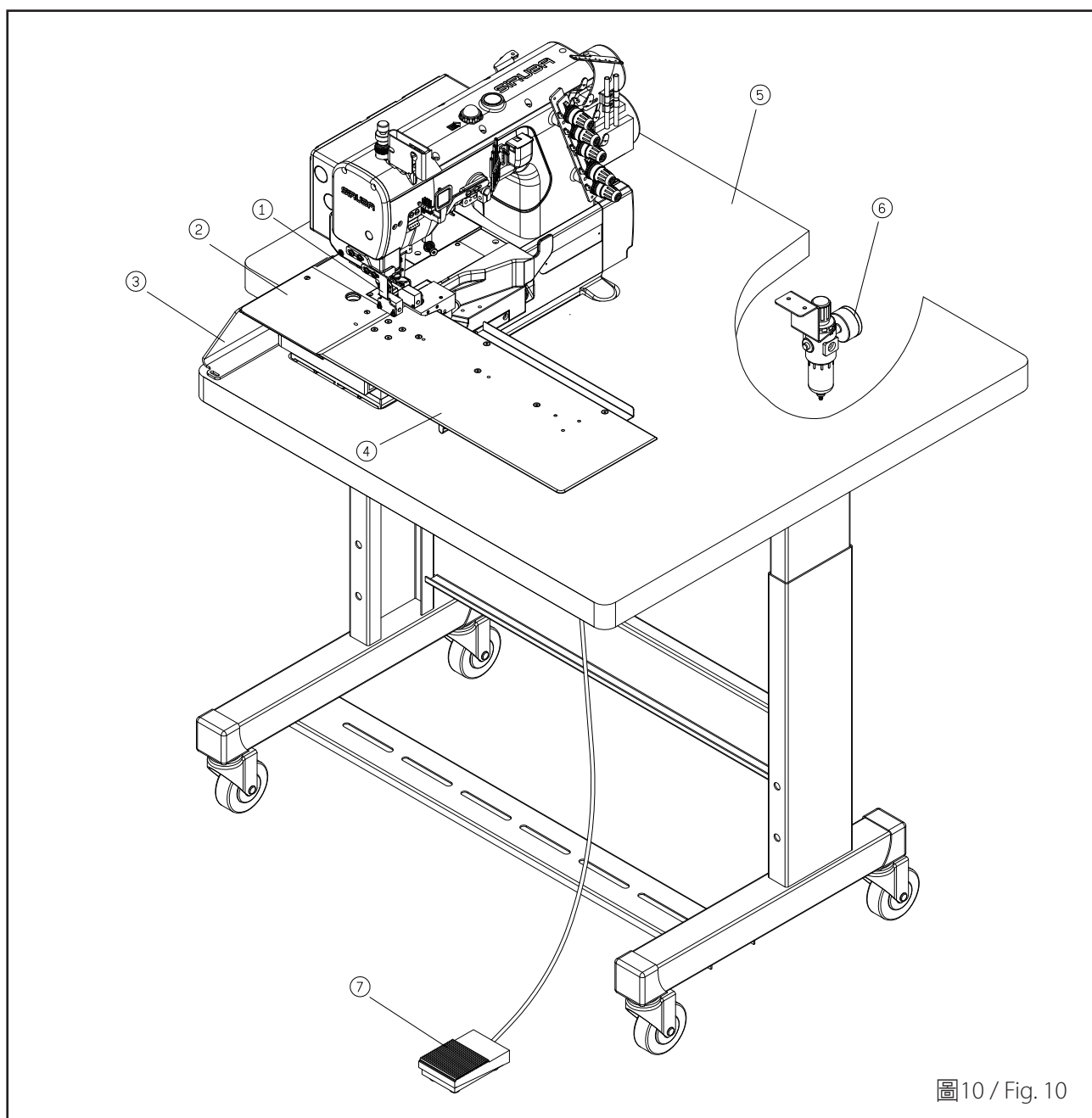
ADJUSTMENT

1. 下摺布寬度調整 (圖11)、(圖12)：

- (1.) 鬆開螺絲 ① *2 左右移動導布片 ② 可調整下摺布寬度，往右移下摺布寬度加大（數字越大），往左移下摺布寬度減少（數字越小）。
- (2.) 鬆開螺絲 ③ *3 左右移動導布架 ④ 可調整下摺布寬度，往右移下摺布寬度增大，往左移下摺布寬度減少。

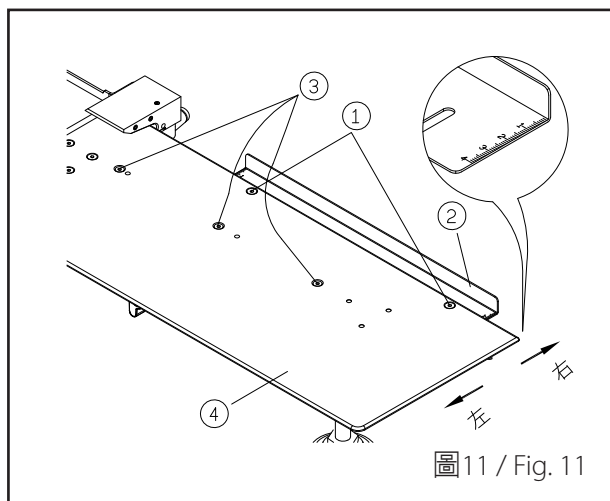

1. Adjust the width of the down-folded cloth (Fig. 11), (Fig. 12)：

- (1.) Loosen screws ① *2, and move fabric guide plate ② to adjust the width of the down folded cloth. When the fabric guide plate s moved rightward (the number is bigger), the width of the down-folded cloth increases. When the fabric guide plate s moved leftward (the number is smaller), the width of the down folded cloth decreases.
- (2.) Loosen screws ③ *3 and move fabric guide frame ④ to adjust the width of the down-folded cloth. When the fabric guide frame is moved rightward, the width of the down-folded cloth increases. When the fabric guide frame is moved leftward, the width of the down-folded cloth decreases.

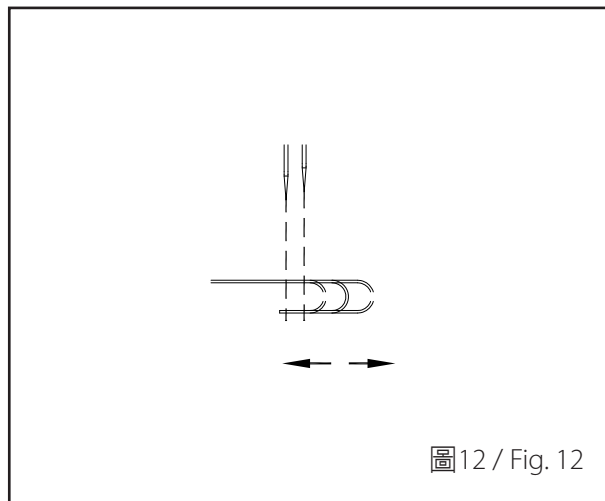

2. 依布料厚度調整（圖13）：

鬆開螺絲 ① 移動導布塊 ②，布料較厚時往右移動。

2. Adjust in accordance with the thickness of the fabric (Fig. 13):

Loosen screw ① and move fabric guide block ②. If the fabric is thicker, move the fabric guide block rightward.



圖13 / Fig. 13

3. 留料量調整（圖14）、（圖15）：

鬆開螺絲 ① 可左右移動固定片 ② 調整布料的留料量，往左移留料量增大，往右移留料量減少。

3. Adjust the amount of the residue (Fig. 14), (Fig. 15):

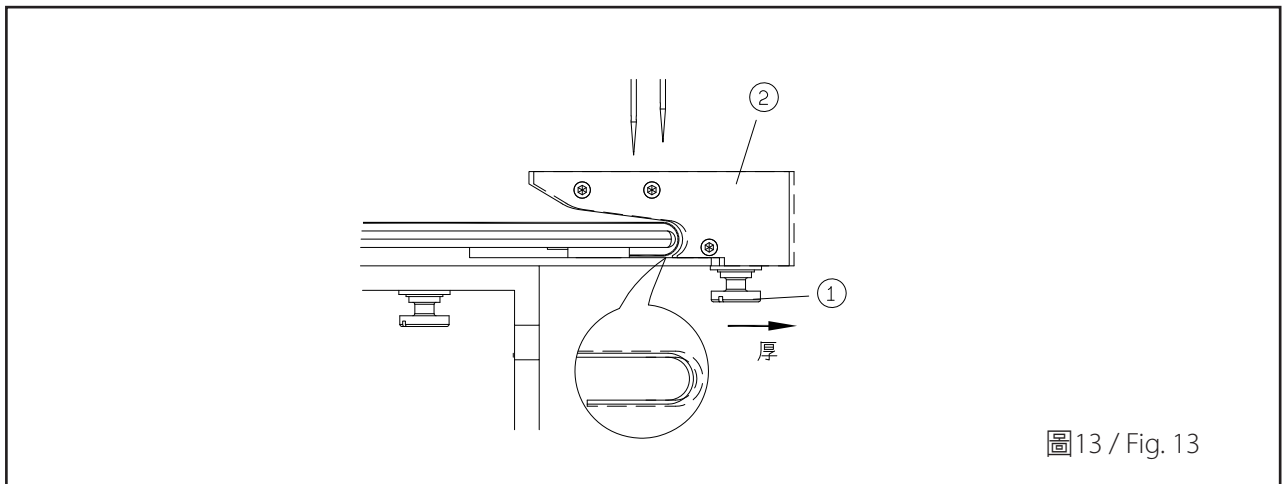
Loosen screw ① and move fixed plate ② to adjust the amount of the residue of the fabric. When the fixed plate is moved leftward, the amount of residue increases. When the fixed plate is moved rightward, the amount of residue decreases.



圖14 / Fig. 14



圖15 / Fig. 15

4. 風量調整：

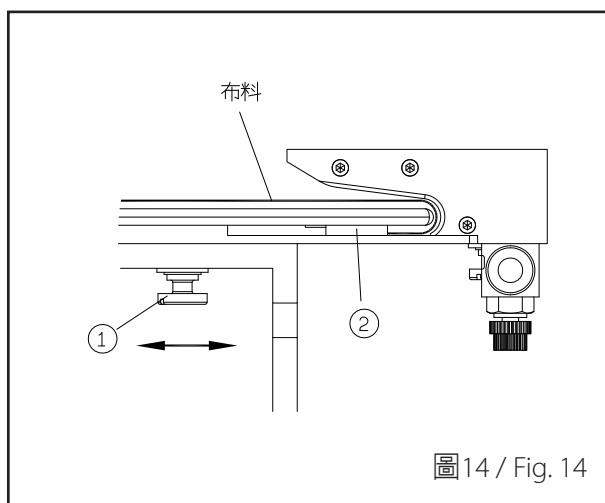
鬆開固定螺帽 ① 可調整吹氣量，往順時針方向轉風量變小，往逆時針方向轉風量變大。
(圖16)

4. Adjust the air volume:

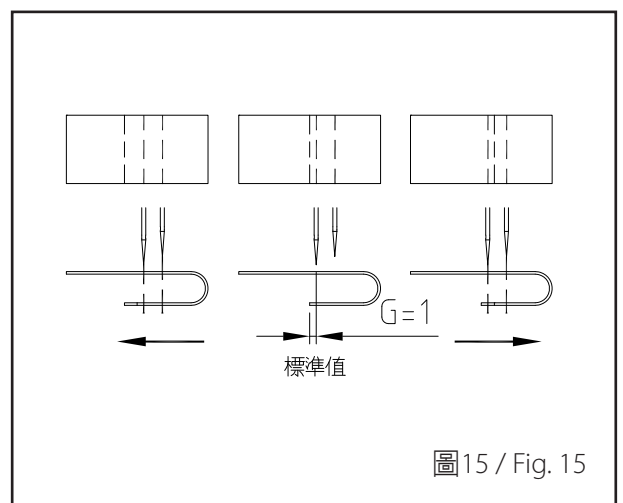
Loosen fixed nut ① to adjust the air volume. When the nut is turned clockwise, the air volume decreases. When the nut is turned counterclockwise, the air volume increases. (Fig. 16)

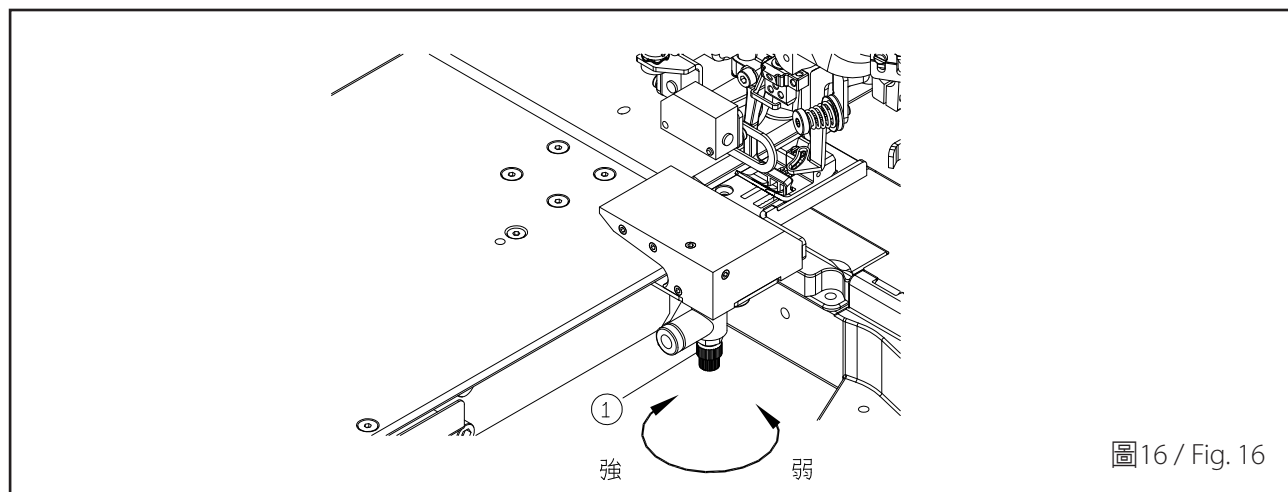

保養及調整

MAINTENANCE AND ADJUSTMENT

鬆開固定鈕 ① 可向後移動導布架 ② 翻開前蓋 ③ 做保養及調整。(圖17)

Loosen the fixed knob ① to move fabric guide frame ② and open the front cover ③ to maintain the machine and make an adjustment. (Fig. 17)

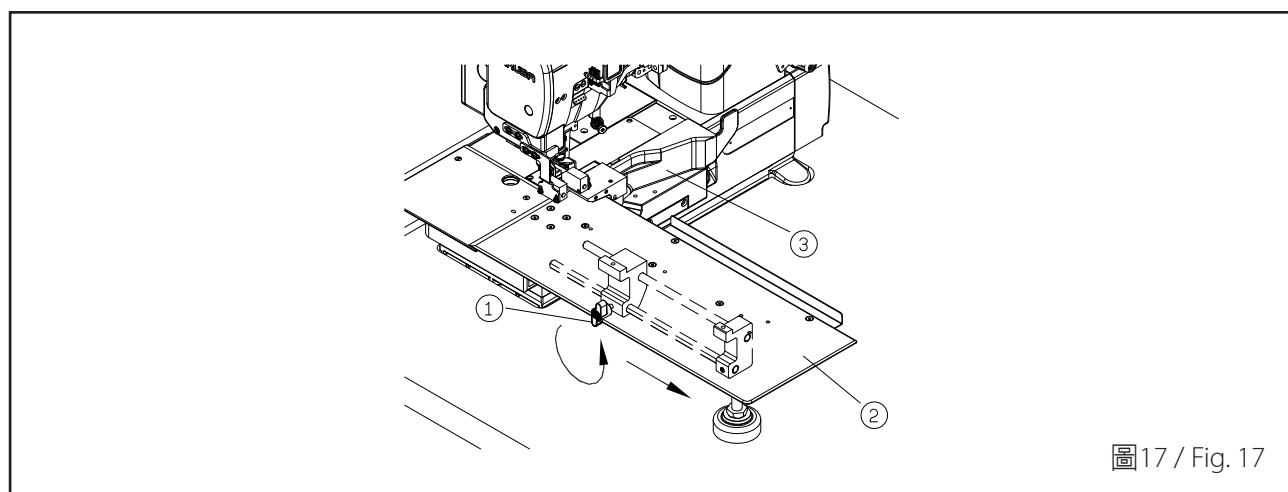

緊急停止開關裝置

EMERGENCY STOP SWITCH

車縫時按下緊急停止開關 ①，縫紉機將會停止車縫。(圖18)

Press the Emergency stop switch ① to stop operation. (Fig. 18)



圖18 / Fig. 18

控制箱功能配置圖

THE CHART OF THE FUNCTIONS OF THE CONTROL BOX

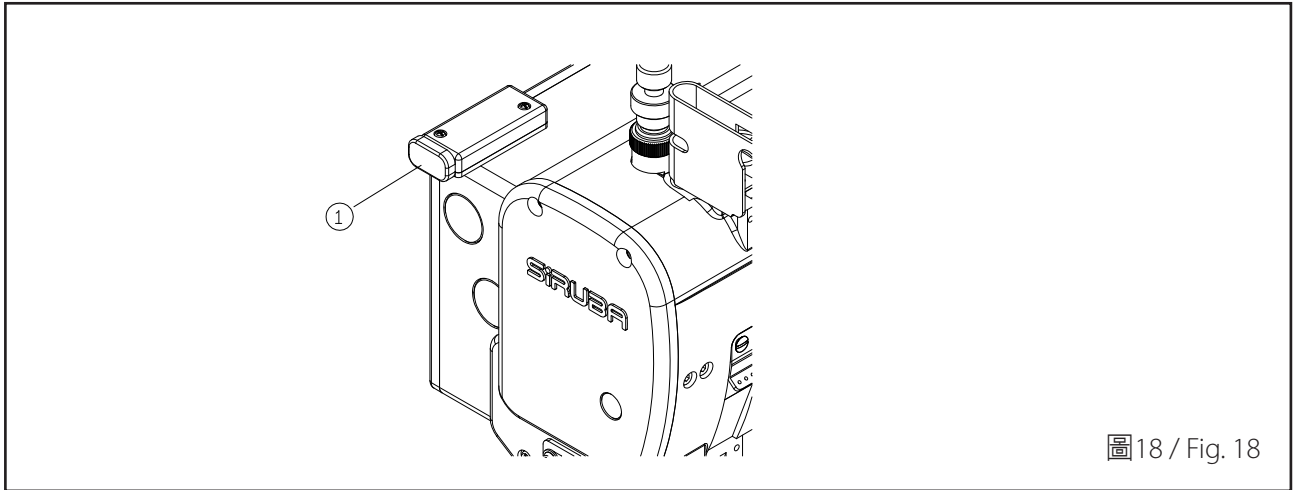
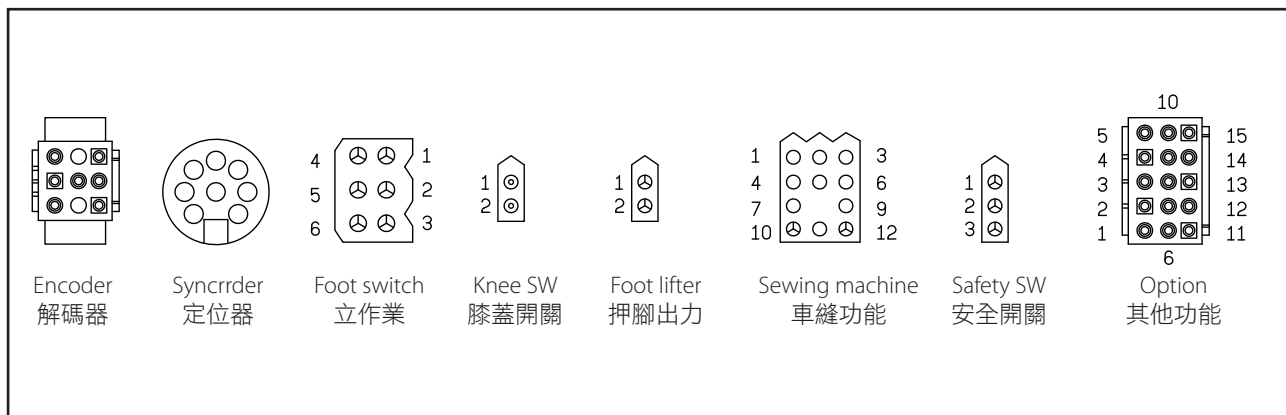

參數號碼 Parameter No.	內容 Content	說明 Description
001 H	4000	車縫速度 Sewing speed.
009 A	4000	車縫速度 Sewing speed.
093 W2	1000ms	動作結束後之吹風時間 The time of blowing after the motion comes to an end.
099 SE	ON	是否使用電眼 Whether to use the sensor or not.
102 SE	10	加工物離開電眼後之針數 The number of stitches remaining after the processed object leaves the electric eye.
104 PSU	1	緊急停止針數 The number of stitches remaining after the machine stops urgently.
114	110	針上停止角度 The angle of the highest position of needle bar.
122 HL	4000	最高車縫速度限制 The maximum sewing speed limit.

規格件表 CONVERSION CHART

MODEL 機型	SUB-CLASS 規格	NEEDLE CLAMP 針座	NEEDLE PLATE 針板	MAIN FEED DOG 主送具	DIFF. FEED DOG 差送具	TOP FEED DOG 上送具	PRESSER FOOT 壓具	LOOPER 勾針	SPREADER 上叉	NEEDLE 使用針
W121/FFT/FHA	240	M5240	E7240FL	D7240F	H7240F	F7240F	P7240F-A	ME28	MH41	UYX128GAS#10
	248	M5248	E7248FL	D7356F	H7356F	F7356F	P7248F-A			
	356	M5356	E7356FL				P7356F-A			
	364	M5364	E7364FL				P7364F-A			
W121/FFT/FHA /UTG(UTJ)	240	M5240	E7240FL	D7240F	H7240F	F7240F	P7240F-A	ME28	MH41	UYX128GAS#10
	248	M5248	E7248FL	D7356F	H7356F	F7356F	P7248F-A			
	356	M5356	E7356FL				P7356F-A			
	364	M5364	E7364FL				P7364F-A			
W122/FFT/FHA	240	M5240	E7240FM	D7240F	H7240F	F7240F	P7240F-A	ME28	MH41	UYX128GAS#10
	248	M5248	E7248FM	D7356F	H7356F	F7356F	P7248F-A			
	356	M5356	E7356FM				P7356F-A			
	364	M5364	E7364FM				P7364F-A			
W122/FFT/FHA /UTG(UTJ)	240	M5240	E7240FM	D7240F	H7240F	F7240F	P7240F-A	ME28	MH41	UYX128GAS#10
	248	M5248	E7248FM	D7356F	H7356F	F7356F	P7248F-A			
	356	M5356	E7356FM				P7356F-A			
	364	M5364	E7364FM				P7364F-A			
U131/FFT/FHA /FHK	248	M5248	E7248FL	D7240F	H7240F	F7240F	P7248U-A	ME28	—	UYX128GAS#10
	256	M5356	E7356FL	D7356F	H7356F	F7356F	P7256U-A			
	264	M5364	E7364FL				P7264U-A			
U132/FFT/FHA /FHK	248	M5248	E7248FM	D7240F	H7240F	F7240F	P7248U-A	ME28	—	UYX128GAS#10
	256	M5356	E7356FM	D7356F	H7356F	F7356F	P7256U-A			
	264	M5364	E7364FM				P7264U-A			

PARTS LIST FOR FHK GROUP

PARTS LIST FOR FHK GROUP

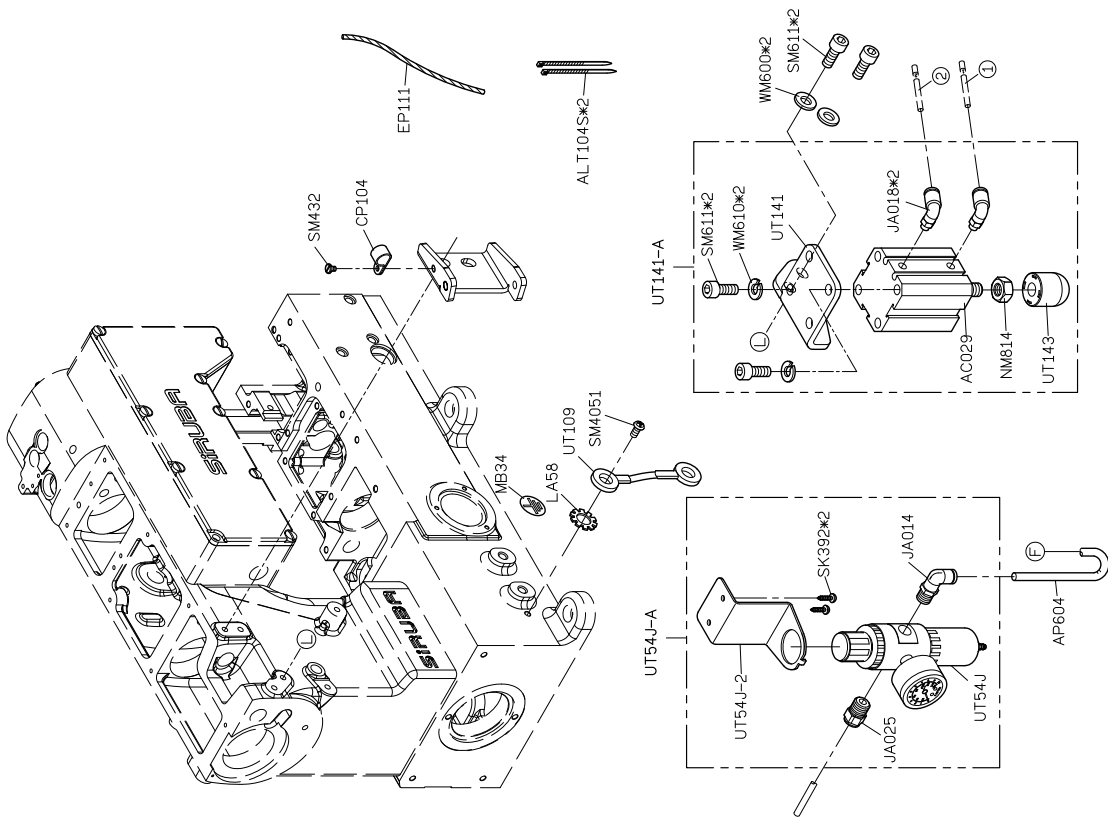
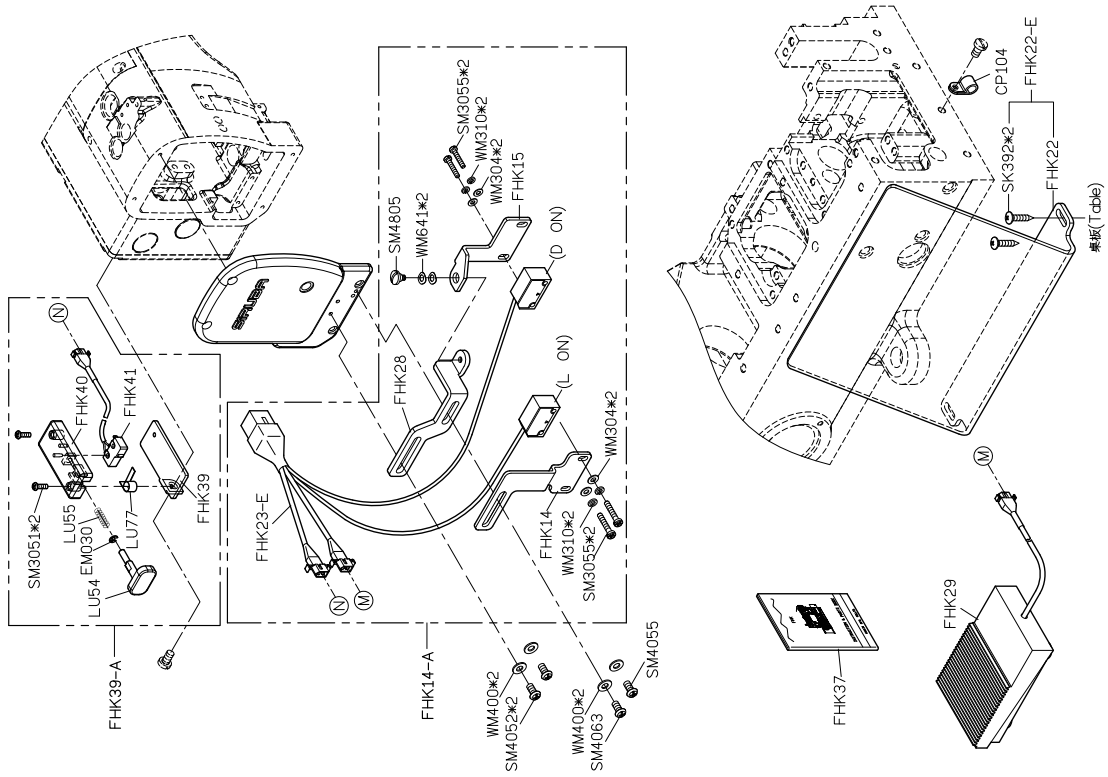

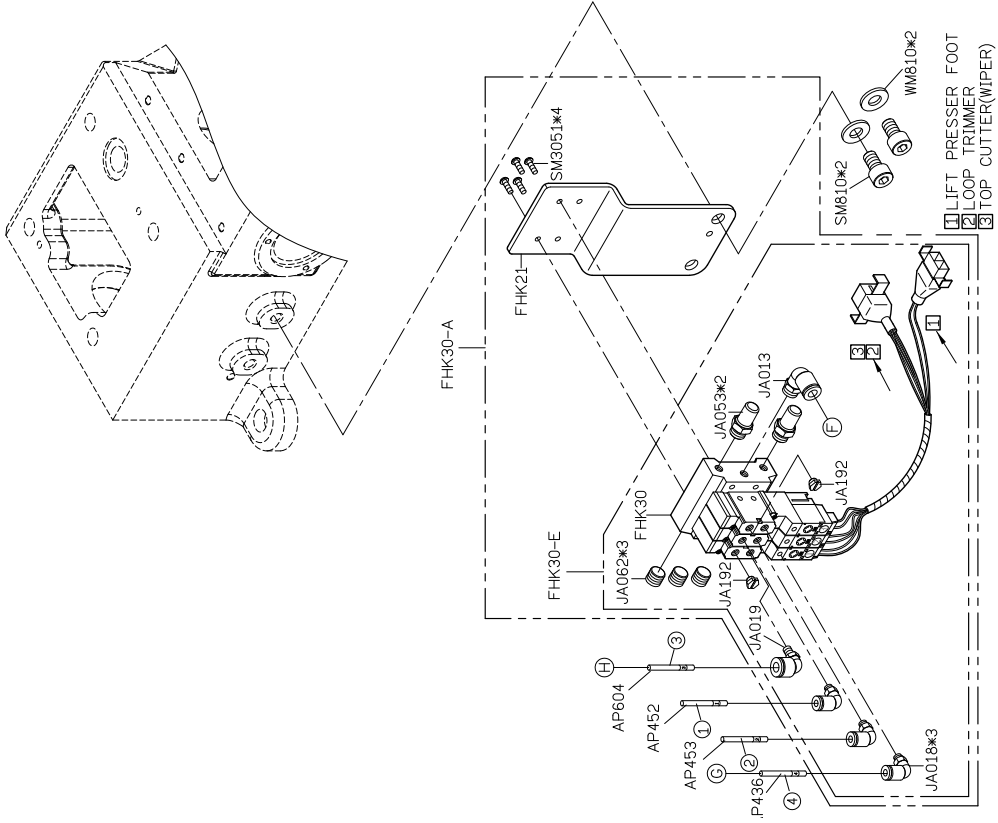
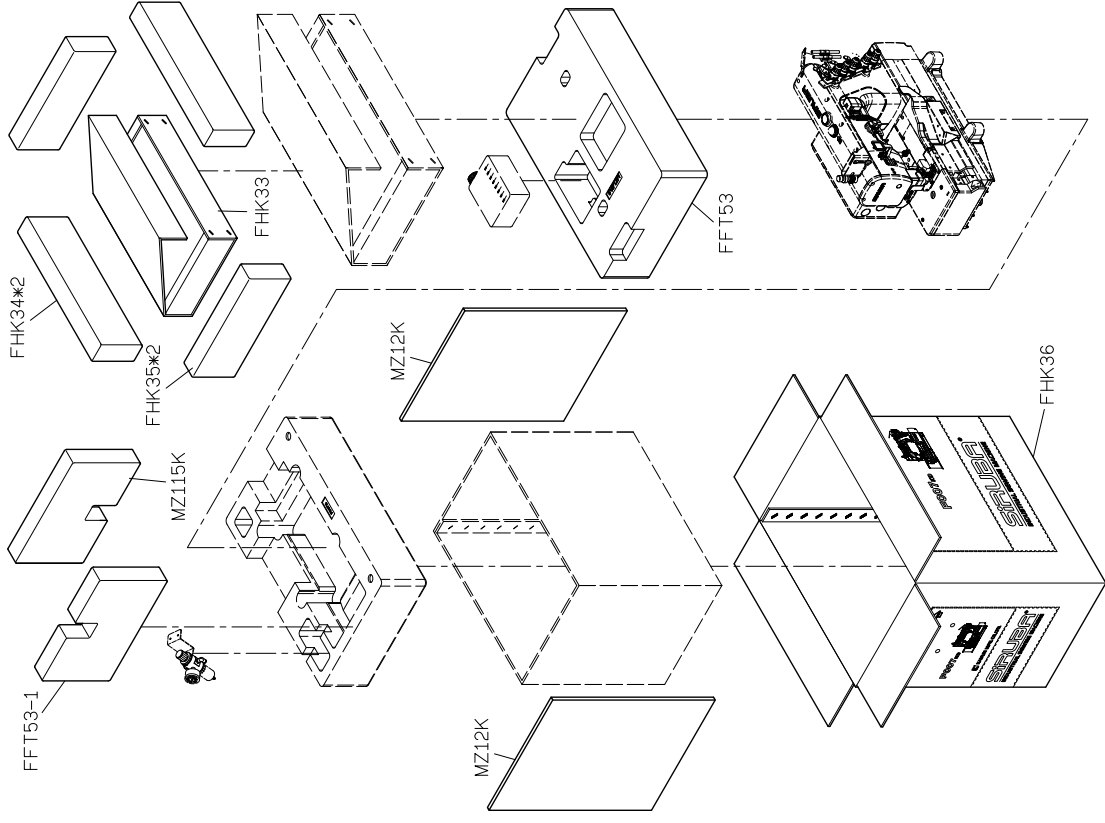

PARTS LIST FOR FHK GROUP

PARTS LIST FOR FHK GROUP



F007K-FHK

高林股份有限公司 KAULIN MFG. CO., LTD.